

**FM LEAN-Neuheit!**

**Monitor & Tablet Holders  
incl. mounting set  
for aluminium profiles with groove**

See the difference

An ergonomically optimized workspace increases both comfort and efficiency. Our new monitor and tablet holders provide a **flexible and stable solution for ideal positioning of your screens and tablets**. Made from high-quality materials, they guarantee longevity and secure support—even with intensive use.

Our holders can be easily mounted on profile systems with groove and other common attachment points. Thanks to **individually adjustable tilt and swivel angles**, every screen can be optimally aligned to promote ergonomic posture and relaxed working conditions. Whether in the **office, production, or home office**—our holders ensure maximum comfort everywhere.

In addition to keeping **workspaces organized according to the LEAN 5S principle**, our holders also support workplace health. Thanks to customizable height and angle adjustments, they perfectly adapt to employees' needs, reducing neck strain and fatigue. This, in turn, increases **long-term health and improves work quality**—no more makeshift solutions or wobbly screens. With our monitor and tablet holders, everything **stays stable, flexible, and perfectly tailored to the user**.

**What Makes Our Monitor & Tablet Holders Special?**

- **High Precision:**  
Robust construction for secure support
- **Easy Installation:**  
Quickly mounted & flexibly adjustable
- **Ergonomics:**  
Adjustable tilt & swivel angles
- **Compatibility:**  
Suitable for various screen & tablet sizes
- **Durability:**  
High-quality materials for long-term use

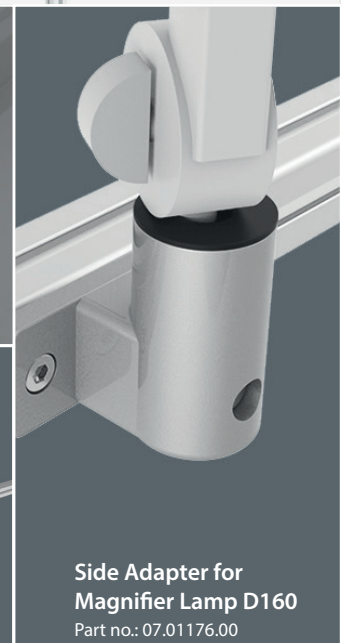
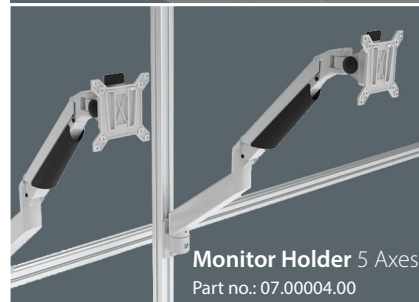
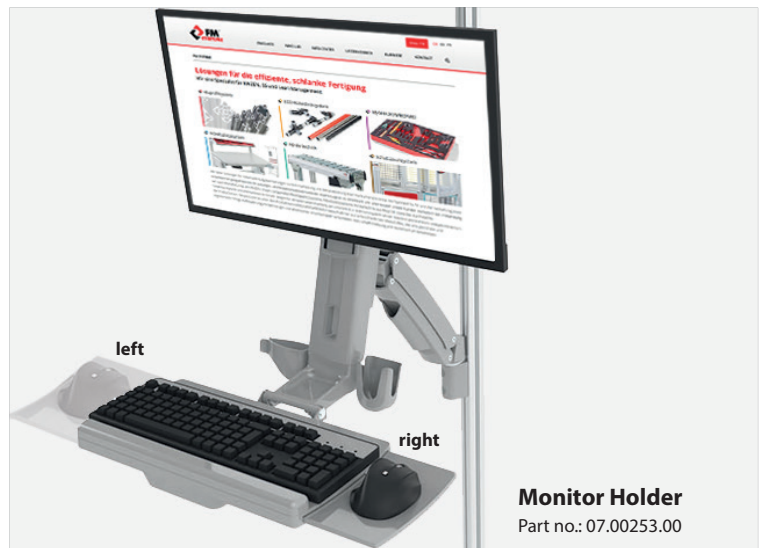

**LEANPLUS**

- Process Standardization**  
Simple installation and modular design
- 5S Principle**  
Organized workspace with fixed positions for monitors & tablets
- Waste Reduction**  
Minimized unnecessary movement & waiting times
- Ergonomics**  
Optimal screen positioning for improved posture

Optimize Your Workspace with Our System Arms.  
Securely hold monitors, tool holders, grab containers,  
and tablets in place.

**LEARN MORE NOW!**

## Technical Specifications

# Monitor & Tablet Holders incl. mounting set

### Materials:

- Monitor/tablet holder: Steel / Aluminum / PA Plastic
- Cable management cover: Plastic
- Mounting flange: Aluminum die-cast
- Screws: Steel
- Joint: Zinc die-cast

### Color Options:

- Monitor/tablet holder: Gray / Aluminum-colored / Black
- Cable management cover: Gray / Black
- Mounting flange: Aluminum-colored
- Clamping lever: Black

## Monitor Holder as a complete system



07.00253.00	<b>492,90 € / Stk.</b> from 1 pcs. (1 pu)	<b>478,55 € / Stk.</b> from 10 pcs. (10 pu)
-------------	--	--

## Monitor Floating Arm 40/45



07.00363.00	<b>811,39 € / Stk.</b> from 1 pcs. (1 pu)	<b>787,76 € / Stk.</b> from 10 pcs. (10 pu)
-------------	--	--

## Monitor Holder 40/45 with 4 axes

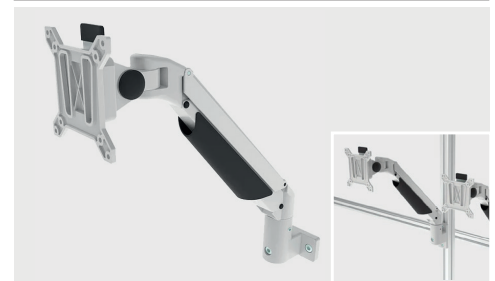

07.00364.00	<b>216,86 € / Stk.</b> from 1 pcs. (1 pu)	<b>210,55 € / Stk.</b> from 10 pcs. (10 pu)
-------------	--	--

07.00365.00	<b>259,82 € / Stk.</b> from 1 pcs. (1 pu)	<b>252,26 € / Stk.</b> from 10 pcs. (10 pu)
-------------	--	--

## Monitor Holder 40/45 with 5 axes



07.00004.00	<b>256,32 € / Stk.</b> from 1 pcs. (1 pu)	<b>248,84 € / Stk.</b> from 10 pcs. (10 pu)
-------------	--	--

07.00005.00	<b>306,80 € / Stk.</b> from 1 pcs. (1 pu)	<b>297,86 € / Stk.</b> from 10 pcs. (10 pu)
-------------	--	--

## Monitor Mount 40/45



07.00006.00	<b>65,84 € / Stk.</b> from 1 pcs. (1 pu)	<b>63,93 € / Stk.</b> from 10 pcs. (10 pu)
-------------	---	---

## Monitor Mount 40/45 with clamping lever

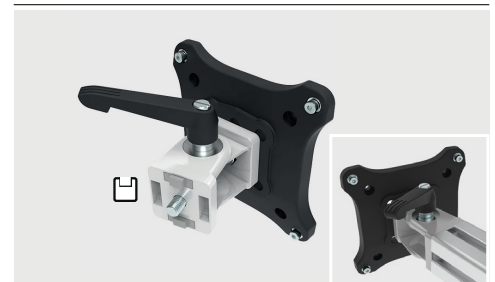

07.00007.00	<b>32,05 € / Stk.</b> from 1 pcs. (1 pu)	<b>31,12 € / Stk.</b> from 10 pcs. (10 pu)
-------------	---	---

07.00008.00	<b>32,97 € / Stk.</b> from 1 pcs. (1 pu)	<b>32,01 € / Stk.</b> from 10 pcs. (10 pu)
-------------	---	---

## Tablet Holder



07.00009.00	<b>55,04 € / Stk.</b> from 1 pcs. (1 pu)	<b>53,44 € / Stk.</b> from 10 pcs. (10 pu)
-------------	---	---

07.00010.00	<b>55,04 € / Stk.</b> from 1 pcs. (1 pu)	<b>53,44 € / Stk.</b> from 10 pcs. (10 pu)
-------------	---	---

07.01174.00	<b>55,04 € / Stk.</b> from 1 pcs. (1 pu)	<b>53,44 € / Stk.</b> from 10 pcs. (10 pu)
-------------	---	---

07.00027.00	<b>55,04 € / Stk.</b> from 1 pcs. (1 pu)	<b>53,44 € / Stk.</b> from 10 pcs. (10 pu)
-------------	---	---

07.00028.00	<b>55,04 € / Stk.</b> from 1 pcs. (1 pu)	<b>53,44 € / Stk.</b> from 10 pcs. (10 pu)
-------------	---	---

07.00029.00	<b>55,04 € / Stk.</b> from 1 pcs. (1 pu)	<b>53,44 € / Stk.</b> from 10 pcs. (10 pu)
-------------	---	---

07.00039.00	<b>55,04 € / Stk.</b> from 1 pcs. (1 pu)	<b>53,44 € / Stk.</b> from 10 pcs. (10 pu)
-------------	---	---

## Magnifier Lamp D160 with joint arm



07.01175.00	<b>515,45 € / Stk.</b> from 1 pcs. (1 pu)	<b>500,43 € / Stk.</b> from 10 pcs. (10 pu)
-------------	--	--

## Side Adapter for magnifier lamp D160



07.01176.00	<b>30,35 € / Stk.</b> from 1 pcs. (1 pu)	<b>29,46 € / Stk.</b> from 10 pcs. (10 pu)
-------------	---	---

Prices valid for all orders placed until April 15, 2025.

Looking for more mounting solutions for monitors, grab containers, perforated panels, etc.?

Discover a wide selection in our workplace systems catalog – scan the QR code or click the banner!



**FM SYSTEME**

**Arbeitsplatzsystem**

Erweiterte Arbeitsplatzsysteme für optimale Produktivität, Gesundheit und Sicherheit immer im Fokus

Ergonomisch - Individuell - Nachhaltig

Effizienz in der Nutzung

Das vielseitige Arbeitsplatzsystem von FM unterstützt Sie bei der Umsetzung von ergonomischen, sicherheitstechnischen und produktivitätstechnischen Gesichtspunkten. Besonders in den folgenden Problembereichen sind viele Vorteile zu erwarten: Durch individuelle Anpassungen an Ihren Arbeitsplatz gewährleisten Ihre Mitarbeiter sich eine optimale Arbeitshaltung und -umgebung.

Lebensdauer, Flexibilität und individuelle Anpassung sind die Stärken der FM-Produkte und sorgen für eine langfristige und sichere Nutzung Ihrer Investitionen.

**Anwendungsbereiche**

Grab container | Perforated panel | Monitor holder | Magnifier lamp | Side adapter | Tablet holder

FM SYSTEME